

HIP CREATIVE CONSULTING

CRAFTING INSPIRATIONAL DESIGN
FOR THE MODERN WORLD

CONTENTS

PART I

0 4	Introduction
0 6	About Jamie
0 7	Testimonies
0 8	Our Process
1 2	Phase I - Consultation
1 6	Phase II - Design / Implementation
2 0	Phase III - Product Design
2 4	Phase IV - Fine Art
2 8	Phase V - Showcasing
3 4	Case Study #1 - Joynes Suite
3 8	Case Study #2 - Femme Du Bois
4 2	Case Study #3 - Zaya Sphere

PART II

5 0	Reception	9 8	Sally Bee's
5 4	Long Gallery	1 0 2	Bouji
6 0	Relaxation Room	1 0 6	Huxleys
6 4	Bedrooms	1 1 0	Chalet Renders
7 0	Sanctum	1 1 2	Spa Atrium
7 4	Conservatory Eden	1 1 4	Fine Art / Sculpture
7 6	Conservatory HCH	1 2 3	Contact
8 0	Matt Curtis		
8 4	Spa Shop		
8 6	Slumber Lounge		
9 0	Spa Bed Collection		
9 4	Ibiza		



LUXURY
INTERIOR
DESIGN

HELLO

Introduction

We are creative consultants, and as our name suggests, we provide expert advice for every aspect of a project and build. We pride ourselves on our unlimited creativity, relationships with high quality manufactures and communication with clients. Our love of inspiring, calm and mindful environments has been carved out over 10 years of creating relaxing and tranquil interiors for a number of clients from luxury chalets in the stunning Mont Blanc region to serene spa settings in the UK.

**HIP IS A VIBRANT, INNOVATIVE
& CREATIVE DESIGN SERVICE.**

**WE ARE FORWARD THINKERS, PIONEERS, DESIGNERS, ARTISTS,
INITIATORS, NEGOTIATORS & PROBLEM SOLVERS.**

ABOUT JAMIE

Founder of HiP

The core values of HiP Creative consulting come from its founder Jamie Strachan, who's clear-cut aim is to produce beautiful, high quality and functional design.

As a company, HiP encompasses a creative spectrum spanning across interior architecture and design, illustration, graphic art, brand concepts, sculpture, film production and creative consulting. HiP maintains an ahead-of-the-curve approach whilst remaining sensitive to tradition and heritage.

Running through all creative projects is the instinctive free thinking of fine art and a mindful approach to design.

Our philosophy is underpinned by a core set of values based in honesty, simplicity, form, pattern and a primitive instinct to make good art and design.

For HiP, good design is an amalgamation of four anchor points; client, environment, creative-energy and integrity. Get those four elements right and we believe that the outcome will always be successful!

" Art imitates life. Design can enhance life! I love the freedom to play in these two paradigms. Art is a conceptual process of copying or reproducing and creating a language to describe the way we see and understand things. Design offers an opportunity to enhance our experience, to take us to places we didn't know could exist. "

Andre Elshout

TESTIMONIES

"We asked Hip to come on board as creative consultants to the Barons Eden Group to assist in the major renovations of two of our properties, Hoar Cross Hall and Eden Day Spa. They have since transformed a number of our spa, retail, leisure and hospitality areas throughout both destinations into exceptionally high end and undoubtably memorable interiors for our guests to experience. We are absolutely delighted with the results! Jamie is an extremely tallented individual with the rare ability to work effortlessly with everyone involved and his energy and creative passion is infectiouse! "Their involvement has made all the difference to the success of our renovations and we will use them alot more in furure."

Andre Elshout

"Working alongside HiP has been a great insight into discovering why design is so important when carrying out key projects. Jamie and Becky both offered very expressive and comprehensive knowledge, with great ideas for our various projects. Their approach started with careful research, having in mind the environment around them, which they translated into a vision which in turn they would create a physical space. With a keen eye for detail and professional attitude, I have enjoyed every moment of the work and the wonderful results that HiP has produced."

Gurval Durand GM



OUR PROCESS

We like to be adaptable to our clients' needs and are always excited to guide them in exploring new creative endeavours. In order to outline what we can provide at different stages of a project, we have split our multidisciplinary offering into five simple phases.

Phase I CONSULTATION

We offer a professional, personable and friendly consultation service that assists our clients in the beginning stages of their ideas, helping them to fine-tune the direction of their project. We offer our first consultation free of charge.

Phase II DESIGN / IMPLEMENTATION

Using architectural plans, designs and renders we form the next steps of the project. Working closely with trusted contractors and suppliers, we prepare quotations and time scales ready to be signed off by our clients, we then provide invoices for first and second payment with final balance due on completion.

Phase III PRODUCT DESIGN

Design, refine and build. We are passionate about bespoke design and creating high quality, beautiful products for specific areas. We work with engineers and skilled manufacturers to ensure the very best quality and finish.

Phase IV FINE ART

Our vibrant and timeless portfolio of fine art and sculptures for both residential and commercial environments is continuously developing. Our work is available for purchase and we offer a bespoke service for clients wanting a unique, stand-out piece that are engaging, eye catching and exciting

Phase V SHOWCASING

We offer a styling service that optimises your interior space to capture it through film production, photography and videography.

" The environment that we experience is enhanced and elevated by the presence of art or design.

For me at least, the more honesty and integrity there is within the object or environment, the better the experience "



THE ARTIST PRODUCES TO LIBERATE THE SOUL

AS IT IS THE NATURE OF WATER TO FLOW

PHASE I

Consultation

Over the years we have refined an intuitive design process that is highly flexible and responsive to each clients needs. Nurturing an honest and enjoyable relationship with our clients has proved to yield highly successful results so we are all about energetic productivity, a sense of fun, honesty, hard work and timing. We bring a natural intuition to the table that enhances the development of our understanding of our clients needs and allows us to respond appropriately, always with the aim of delivering admirable results!

“So the process really starts when meeting our clients for the first time and we start as we mean to continue, developing and nurturing a happy and enjoyable working relationship, absorbing and understanding the unique characteristics and requirements of the project ahead, always working with a highly approachable, personable and friendly attitude and welcome creative input from our clients.”

Jamie Strachan





WHAT WE CAN DO FOR YOU

Whether you are looking for architectural drawings, interior style advice, bespoke furniture, fine art to finish a space or a complete redesign we are a creative consultancy service that can offer the whole package. We are not bound by limited resources or ideas and we encourage our clients to dream big and go beyond the boundaries of what they understand to be possible. Not to be put off by the 'what ifs'. Whatever you have in mind, we believe there is a way it can be achieved and we have the energetic drive, means and resources to do that.

CONCEPT STAGE

We understand that the beginning stage of any project can feel overwhelming. At the concept stage we listen carefully to what it is our client wants to achieve and the motivation for wanting to achieve it - this becomes our brief. Once we have made a site visit and gathered some initial information we put together a concept package. This is our preliminary design solution to the brief and helps our client to visualise the design through plans, mood boards and concept drawings.

PHASE II

Design / Implementation

We are multidisciplinary designers. Whether we are producing rough sketches, architectural scale drawings or 3D renders, or just creative advice from the heart—all of our projects are centred around a sense of integrity and careful design and planning using industry recognised resources and technology. Our extensive experience with hotel refurbishment and designing interiors for a wide range of commercial spaces including spas, restaurants, reception areas, communal spaces, bathrooms and bedrooms means we are familiar with working alongside planning officers, surveyors and heritage organisations as well as a wonderful mixture of skilled workers to ensure we take the appropriate steps in the environment we are working with. We are also able to dove tail into architectural projects or building projects as design consultants offering design and build, FF&E and procurement services.

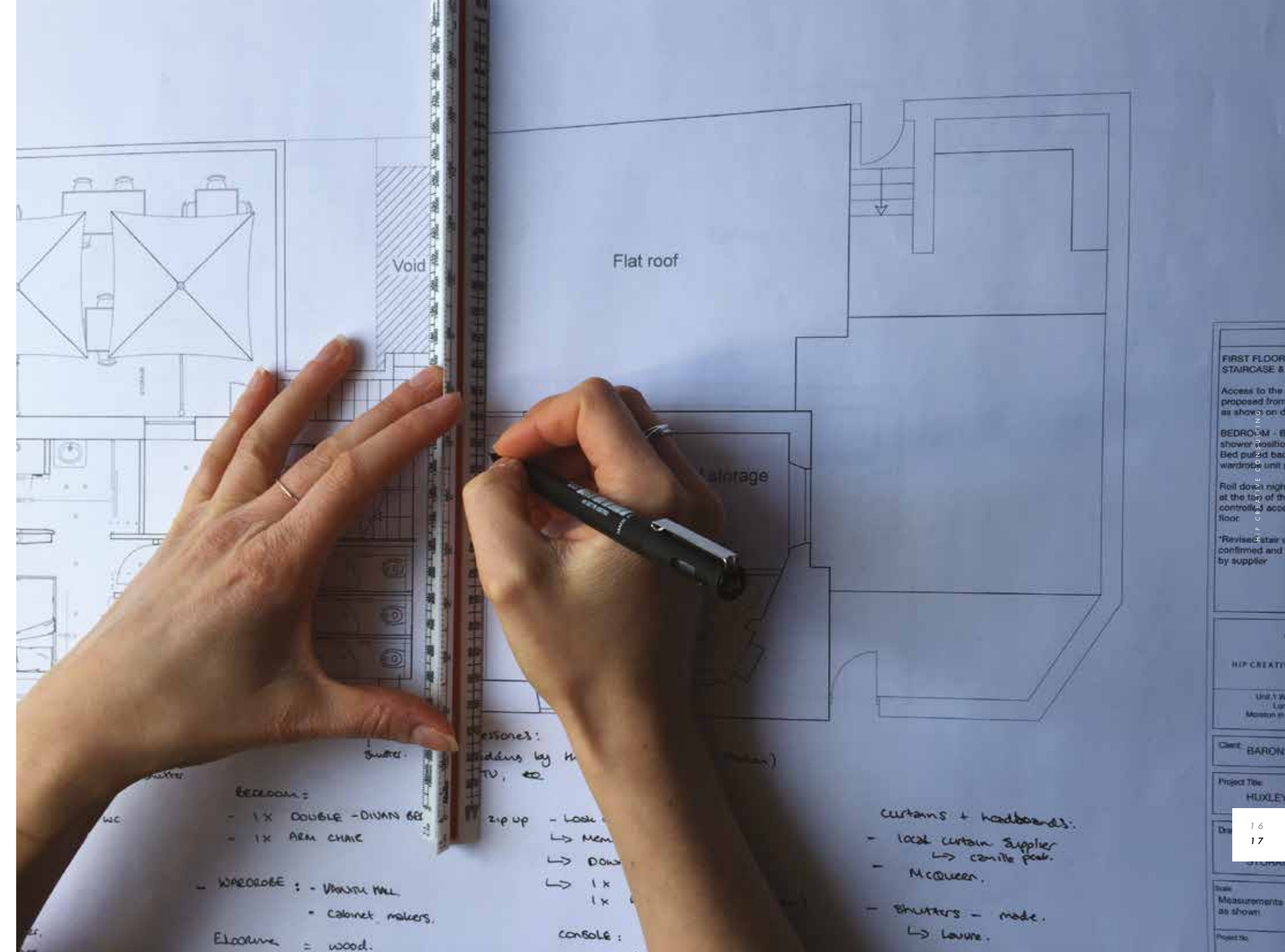

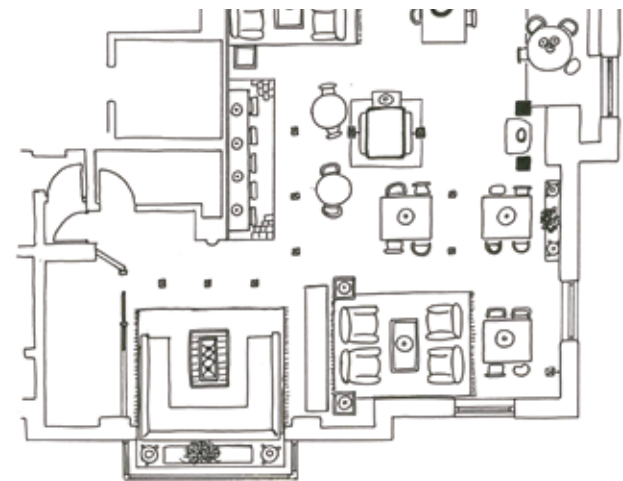
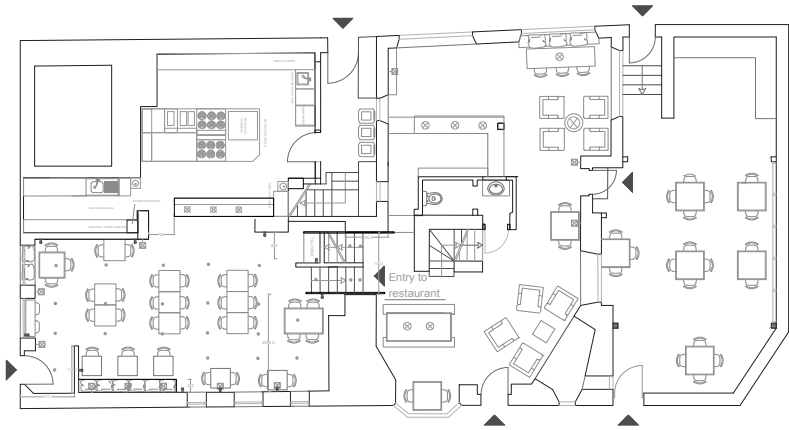

DESIGN

Our highly-skilled and personable in-house design team work closely with our clients and suppliers, not only to maintain excellent communication throughout the design process but also to ensure the best outcome when working with our chosen materials. We are dedicated to the detail. We bring our design concepts to life with a range of design package to suit every budget, these usually include detailed plans, elevations, visuals, style sheets and when necessary 3D renders and models.

PROCUREMENT

We are passionate about sourcing the right product for your project, we always work with the very best local crafts people to manufacture beautiful and bespoke products. When sourcing furniture, whether its on trend, unique in design or a timeless antique, we work extensively with exceptional and trustworthy suppliers from the UK, Europe and around the globe. This enables us to source high quality well priced products whilst keeping to the budget of our client.

IMPLEMENTATION

It is important to us that the implementation stage of a project goes smoothly and it is an enjoyable experience for our clients. We are experienced working respectfully and happily with every person involved in our projects. From contractors to manufacturers, on site maintenance teams to company directors and CEO's our integrity is fundamental to the way we work.

PHASE III

Product Design

Crafting beauty - Our bespoke products are imaginative, responsive and intricately made. For us, there is nothing more exciting than developing a bespoke product from conception through to a viable commercial product. We work with the latest R&D and manufacturing technology to develop outstanding designs and 3D renders. Our experience in designing for luxury interiors for over ten years means we have an exciting portfolio of bespoke furniture ranging from communal seating, restaurant bars, reception desks, spa and post treatment beds to lighting and sculptures. We want our clients to feel they have options and our extensive material library is overflowing with possibilities of colour, fabrics, finishes and textures to provide endless choices! We work closely with our clients to explore options and refine their ideas into a high quality product.

"Our products are ergonomic to their environment."





DESIGN

We focus on the product environment when we design, it's context and it's user. We believe in designing with consideration toward lasting functionality, beauty and durability.

Our process begins with a simple one-to-one meeting where we help to unpick the problem and develop a solution. Our team will develop drawings, collect fabric swatches and where necessary, build prototype models of your product. We have worked on a range of projects varying in size and function so whether it be furniture for a specific space, a bar with an upholstered facade, decorative lighting or an iconic sculpture, our design team have the expertise to develop your idea.

MANUFACTURE

We are considerate about how and where we manufacture our products. We aim to support local tradesmen and work with British manufactures. Our extensive list of highly skilled craftsmen has enabled us to create a vast and creative range of products, sculptures and pieces of furniture.

INSTALL

It's important that anything that we produce for our clients is taken care of from production stage right through to installation. We understand the value of what we are building and that our clients want their finished product to be handled with the up-most care.

PHASE IV

Fine Art

For us, fine art is a life long passion, its in our DNA. Our rich collection has been inspired by our exposure to some of the most beautiful places in the world and thought provoking moments. We believe art is something to celebrate and that it has the ability to take its surroundings to a higher place. This is why we strongly focus on it being one of our main offerings as a company.

Whether a client is looking for a bespoke piece as centre point of a room or something that will set off other colours in a space, we have the creative eye and understanding for high quality art and exquisite sculptures to complete any environment.



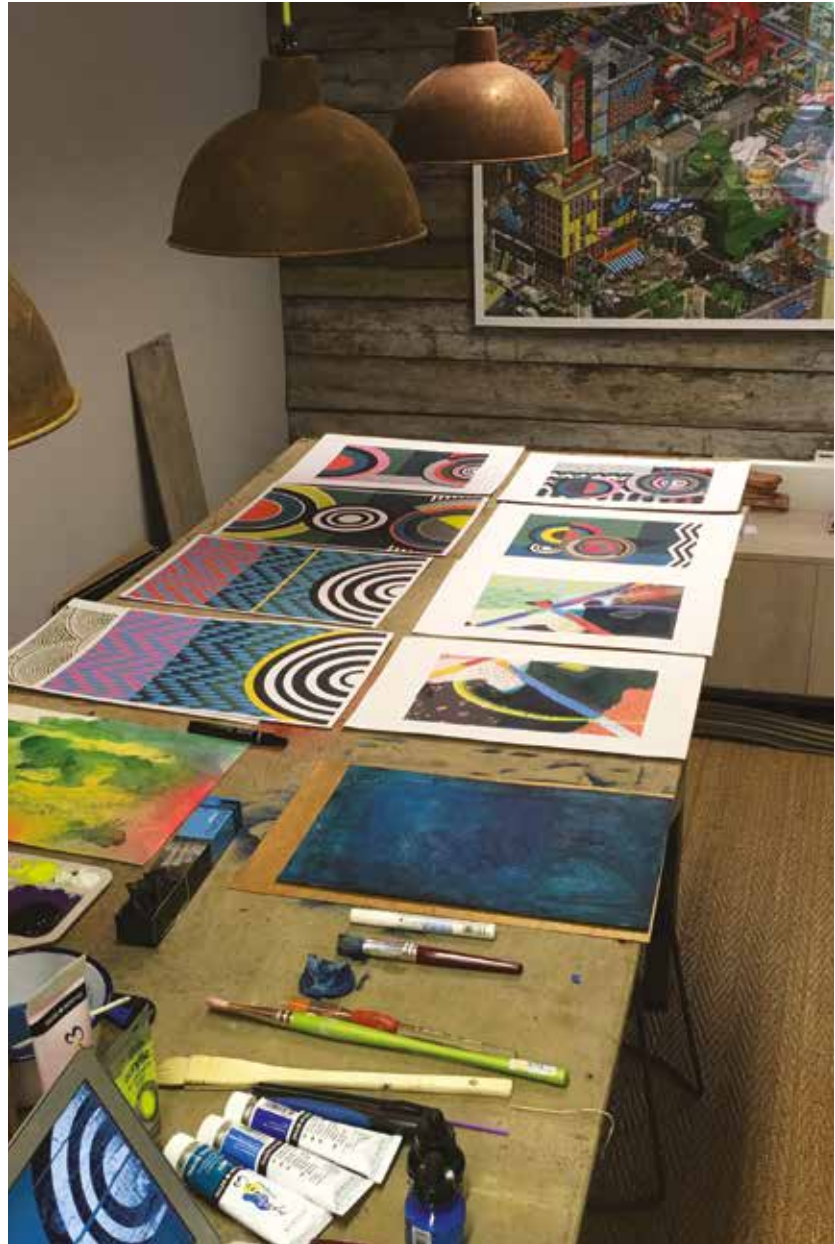

FROM JAMIE

Ever since I trained as an artist I have been passionate about creating bold and original concepts and developing them into a physical form of art. I focus my work around primitive, primordial expressions of human felt experiences and these determine the language of my mark making.

The pieces I produce are a translation of this into vibrant colours, texture and digital techniques. I aim to capture the internal and external connection that is experienced through mindfulness and meditation and bring forth a simplified representation of these elements through my artistic processes.

The process of creating a sculpture or 3D form primarily starts with fluid hand drawing movements and sketching the basic motive of the piece from my mind to the page. With so many opportunities to develop art in our digital age, my processes have developed over my career as an artist and I have grown to love the precision and vibrancy of colours that can be achieved through reworking hand drawn images in digital programs.

PHASE V

Showcasing

Having successfully managed a luxury chalet company for over 10 years we understand that presentation and a high quality representation of what your hotel, property, spa or company can offer is vital. We offer a showcasing service for properties that want to have a visual representation of what they can offer to customers.

"I have worked with HiP as a photographer since their formation. It has been a great relationship particularly as it is always so inspiring and rare to collaborate with a company who are just so passionate. They understand the nuances and fine detail that make all the difference and I always enjoy the challenge of our next shoot together"

Adam Johnston





INTERIOR STYLING

Interior styling for both film and photo shoots - We'll source decorative props and flowers to finish off the look before we capture the space. With the combination of our creative eye and attention to detail we'll optimise your space and deliver high quality showcasing results.

FILM DIRECTION & PRODUCTION

Whether you are looking for drone shots of interior or exterior environments, creative story telling or to simply capture your interior our team can help. Our portfolio boasts film shoots for spas, hotels and luxury properties. We understand the need to work around guests in commercial environments and this is why we are flexible with day or evening shoots. We prepare an efficient filming schedule to keep disruption to a minimum.

PHOTOGRAPHY

Our photography service promises to capture your interior with style and excellence. This is where our clients see our attention to detail at it's finest. We are committed to achieving the best pictures of our client's interiors which is why we work with passionate photographers who go to great lengths to capture their shots and work with the latest, high technology equipment.



WE CAN USE DESIGN TO WORK ON
BEHALF OF THE HUMAN SPIRIT,
TO UPLIFT US PHYSICALLY AND
SPIRITUALLY, TO CONNECT US TO
OUR HUMAN NATURE.

ALAN MOORE

CASE STUDY # 1

Joyes Suite - Hotel Function Room

CLIENT TESTIMONY - Andre Elshout

"We gave HiP a brief to create a vibrant and elegant function space within Hoar Cross Hall to accommodate the growing demand for weddings and events at the hotel. With HiP's multidisciplinary offering they were able to design and deliver every aspect of the project from the bespoke lighting and bar to the furniture and unique carpet, designed exclusively for us.

We could trust everything was being carefully designed and managed by their team. We are extremely pleased with the renovation of the Joyes Suite and the unique offering it provides for events. With the positive feedback we have had we now open it for guests to relax in throughout the day in addition to it's intended purpose."





CASE STUDY #2

Femme Du Bois - Luxury Chalet Refurbishment

PROJECT OVERVIEW

We carried out a complete renovation for the entire downstairs area of the Ferme Du Bois, bringing it up to a luxury standard for guests. It's history of being used as a relaxed family home for many years was transformed into a timeless and high end place for guests to stay in the Chamonix region.

The work required a very tight budget and needed to be carried out in a short space of time to meet with business targets. We furnished all areas of the house and carefully selected antiques that celebrated the character of the property.





CASE STUDY #3

Zaya Sphere - Unique Spa Seating

BRIEF & SOLUTION

Our experience designing for spas led us to channelling energy into products that are tailored to the specific requirements of a commercial spa. We had a lot of fun coming up with solutions for seating, relaxing and post therapy products that are aesthetically pleasing for guests yet extremely practical for maintenance and staff.

We came up with the Zaya Sphere when commissioned by Eden Hall Spa to create a tranquil and relaxing room within their day spa. We understood that space was valuable and so we challenged ourselves to find the balance between privacy for guests whilst still maximising space. The Zaya Sphere provided the solution for both and has been well received by both client and guests.

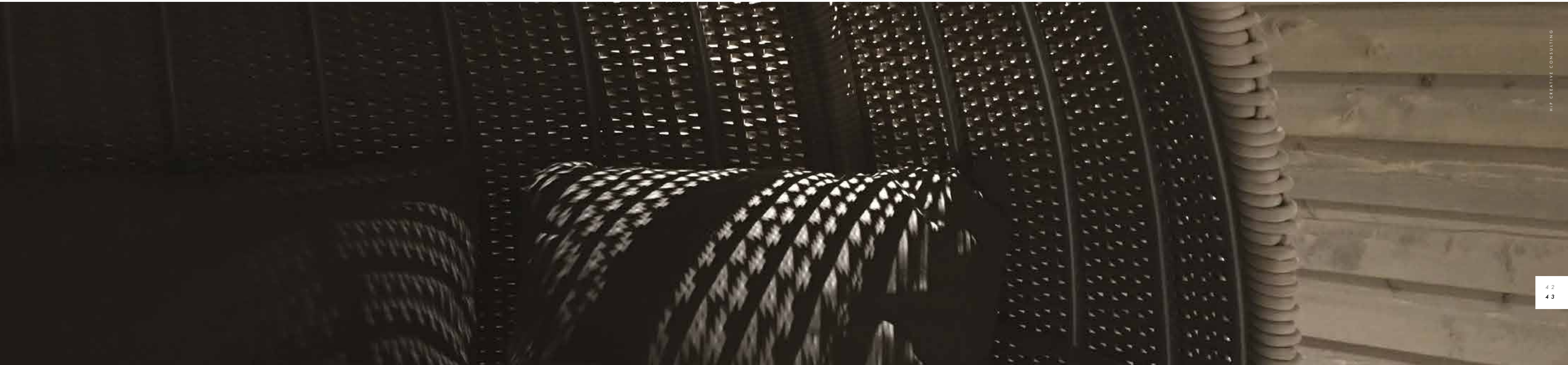

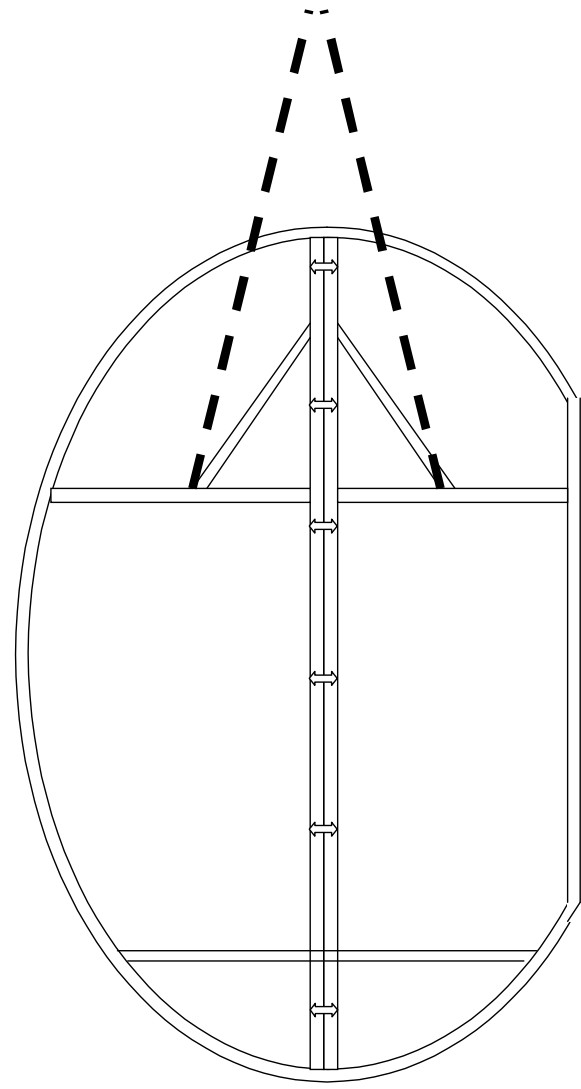



BE CURIOUS ABOUT DESIGN.

**QUESTION HOW THINGS HAVE BEEN
MADE, WHAT MATERIALS YOU CAN SEE,
TOUCH AND DEFINE AS SUBSTANTIAL
CONTRIBUTORS THAT MAKE UP THE FORM
AND FUNCTION OF AN OBJECT, PRODUCT
OR SPACE.**



PART II

The following is a collection
of some of our work

RECEPTION





RECEPTION II

LONG GALLERY







RELAXATION ROOM







B E D R O O M S





SANCTUM





CONSERVATORY EDEN



CONSERVATORY HCH



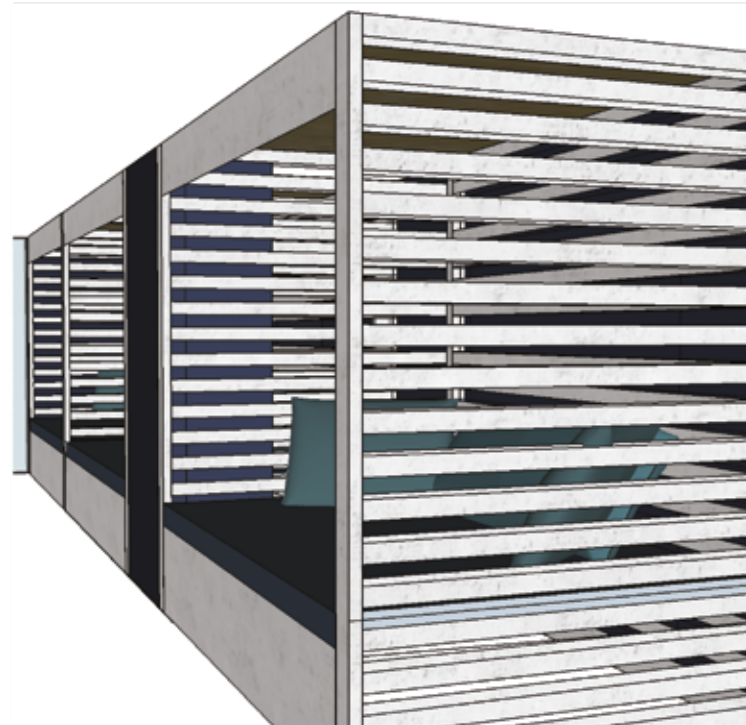
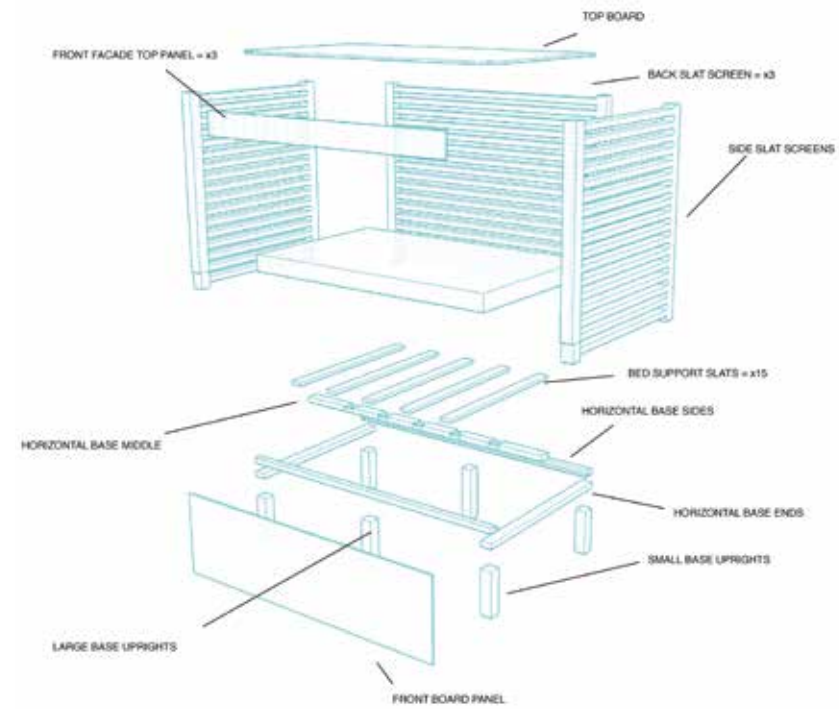
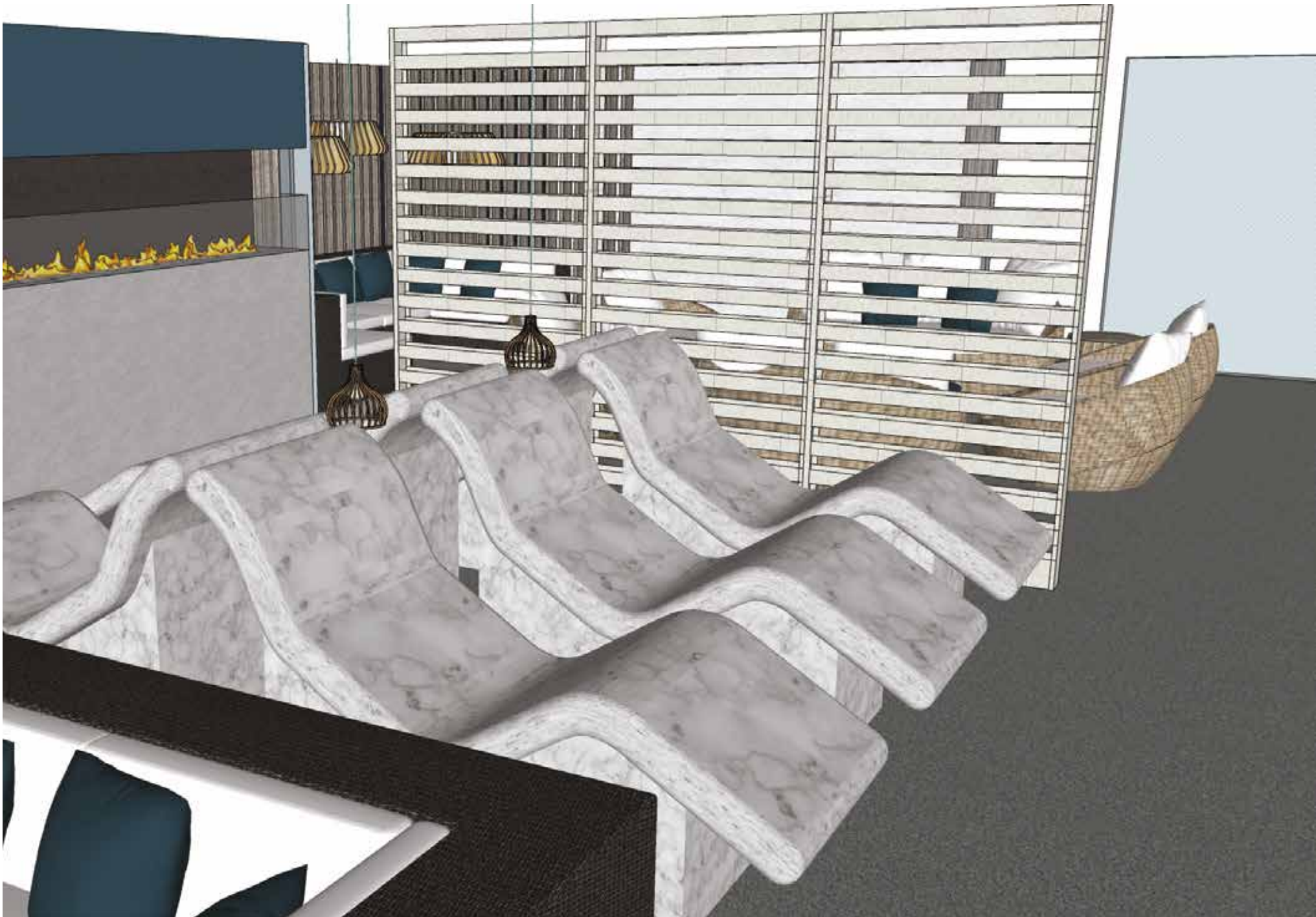

MATT CURTIS



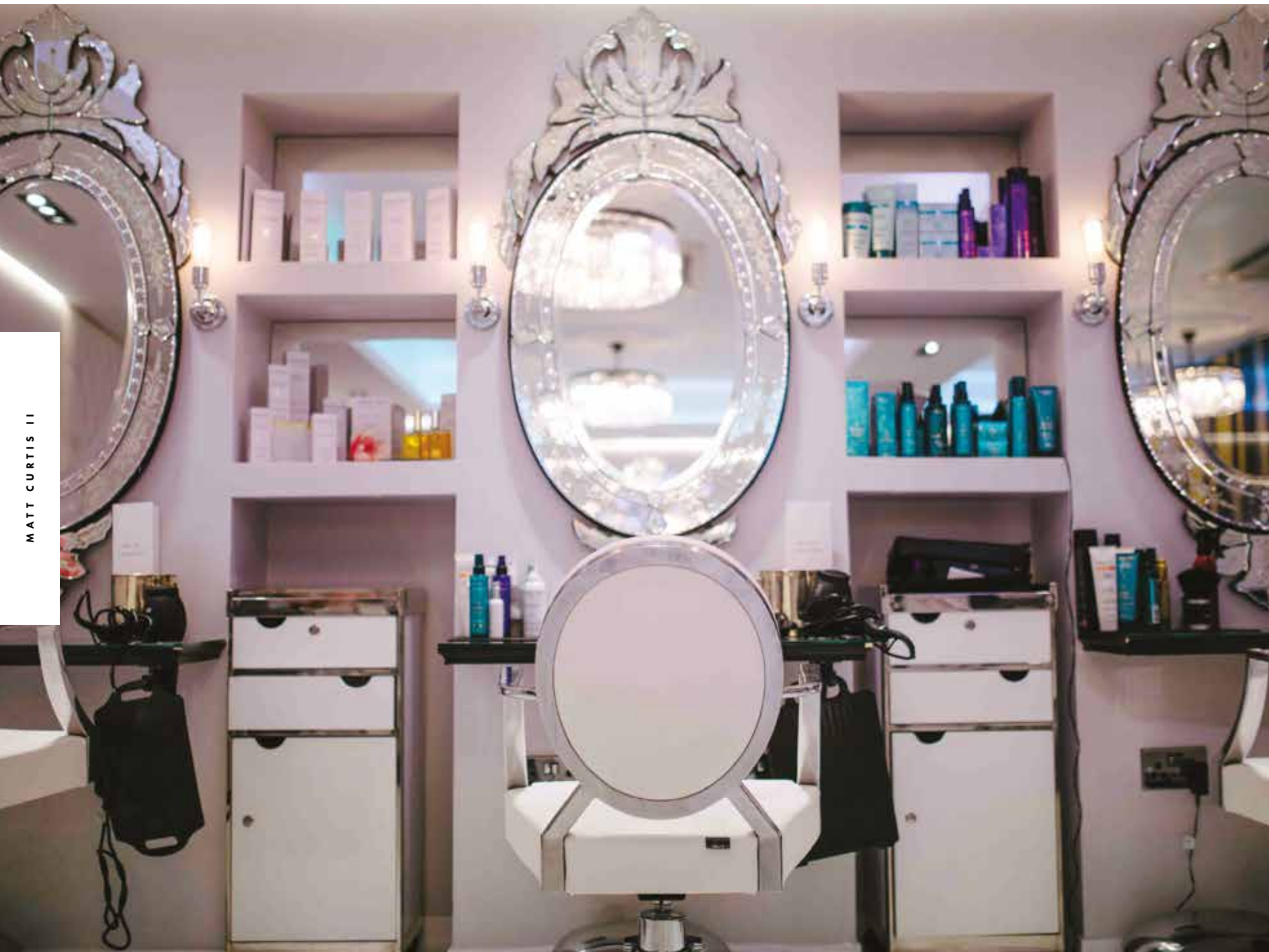

SPA SHOP



SLUMBER LOUNGE

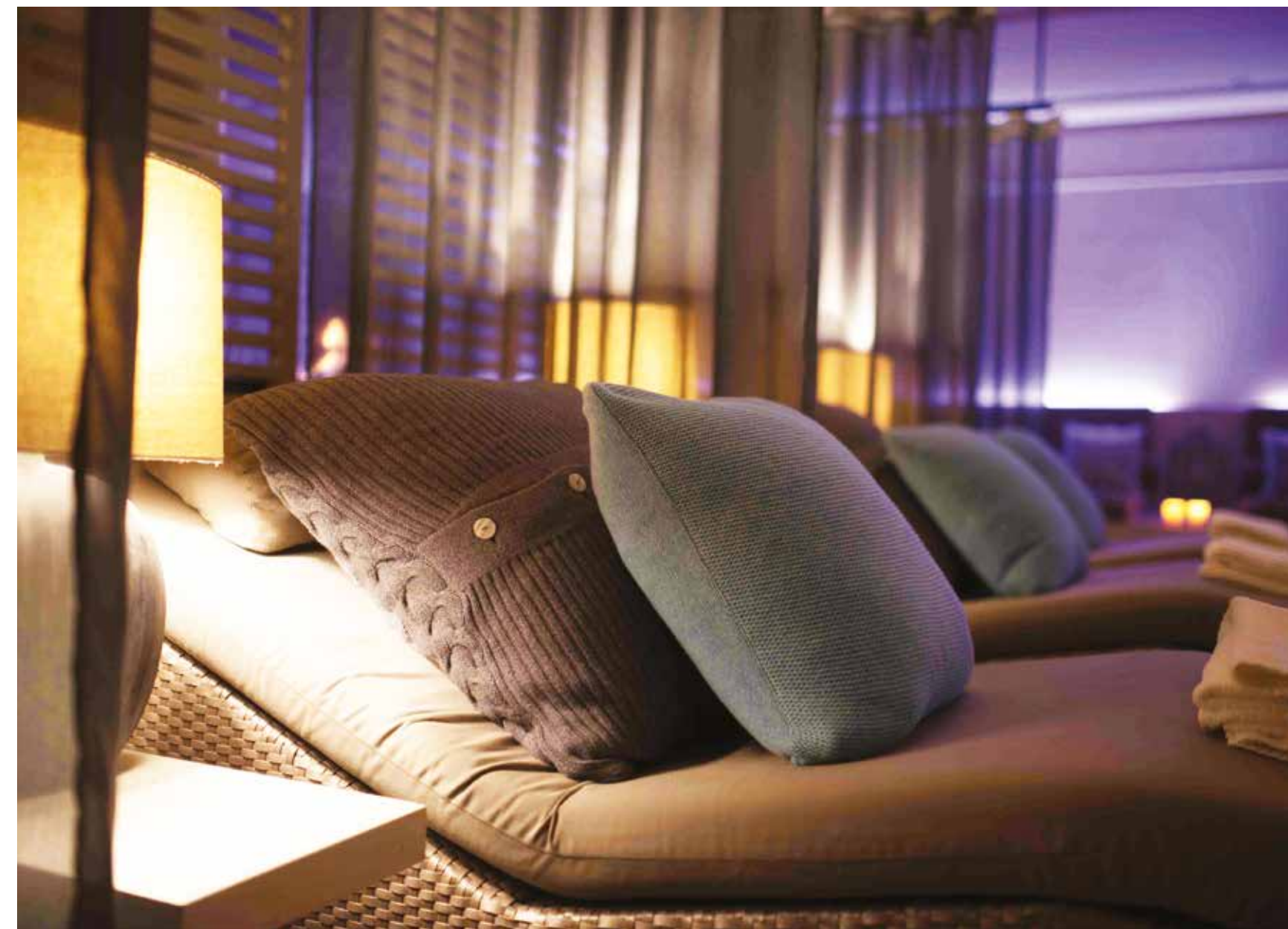



SPA BED COLLECTION

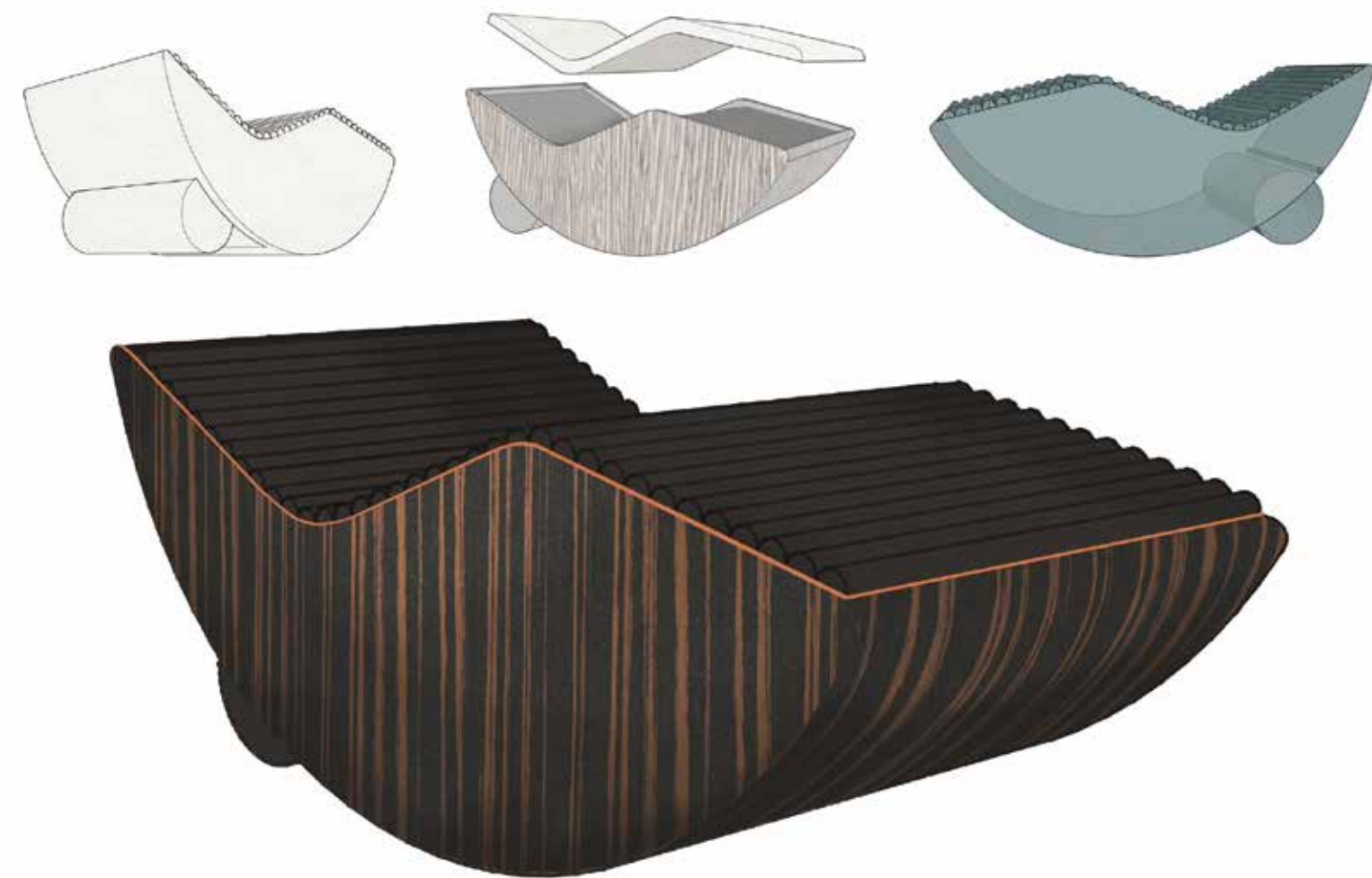

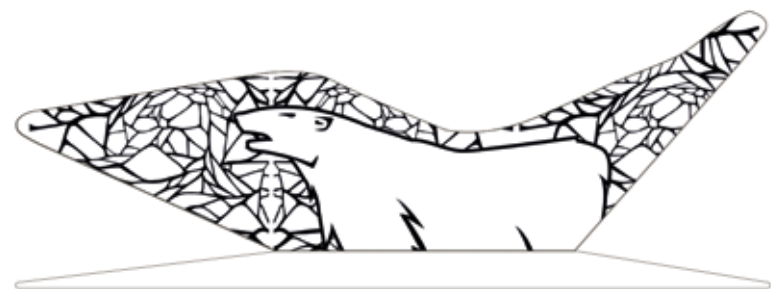

Our original ZAYA Spa Bed has been designed with our commercial clients in mind and is an iconic British product in the spa bed market.

Not long ago we identified the need for a post-treatment spa bed that was both stylish and considerate to the highly functional demands of a commercial spa. A product that was durable and able to withstand the variety of oil-based products used in any spa environment. After a year of intensive trials at Eden Hall Spa, the largest day spa in the UK outside of London, we are proud to be launching the ZAYA Spa Collection as part of our growing product portfolio.

Our entire collection of spa beds are available to order and can be customised to any spa environment with our extensive collection of fabrics and finishes. For further information please see our contact page and get in touch.



Zaya - Mulberry



Zaya - Nordic



Zaya - Igneous



Zaya - Ebony

IBIZA





SALLY BEE'S

Hoar Cross Hall collaborated with nutritionist and health food ambassador Sally Bee to open a restaurant under her established name. HiP worked closely with Sally Bee to understand her brand and the values she wanted to run throughout the interior space. They developed a home-spun, welcoming and warm environment designed around her core values of health, well-being and nourishment "to make a better life". They entwined these factors with rustic aesthetics and produced an exceptional space.

Hoar Cross Hall





SALLY BEE'S II



BOUJI





HUXLEYS

Architecture 1



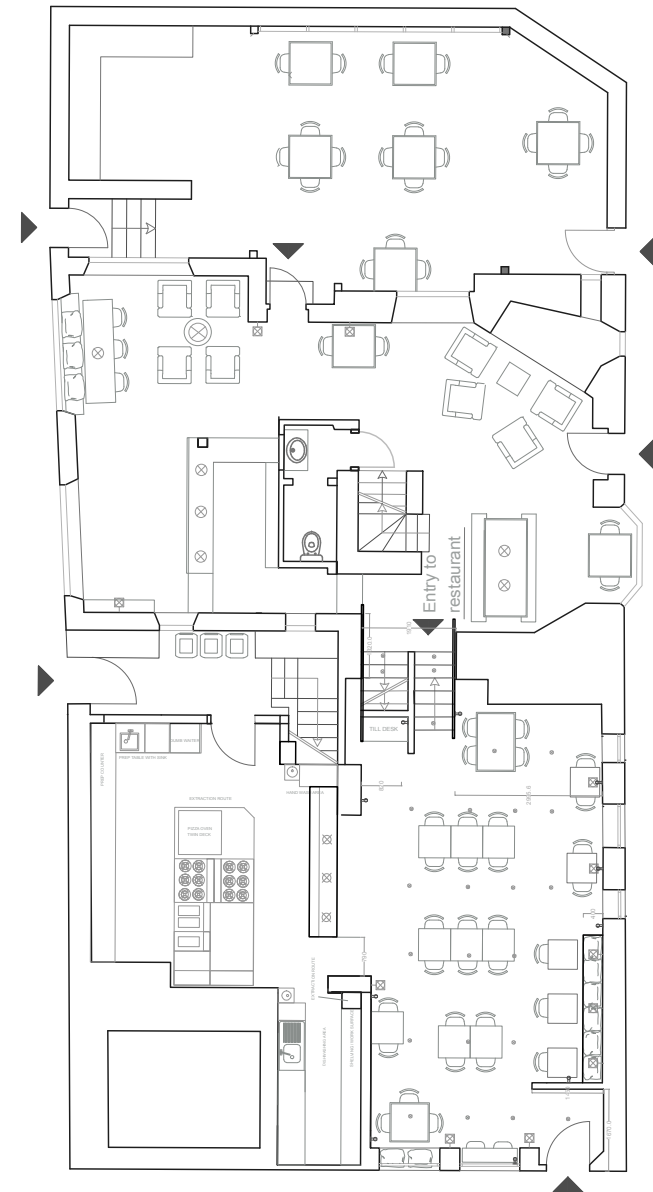

CHALET RENDERS

Architecture 2

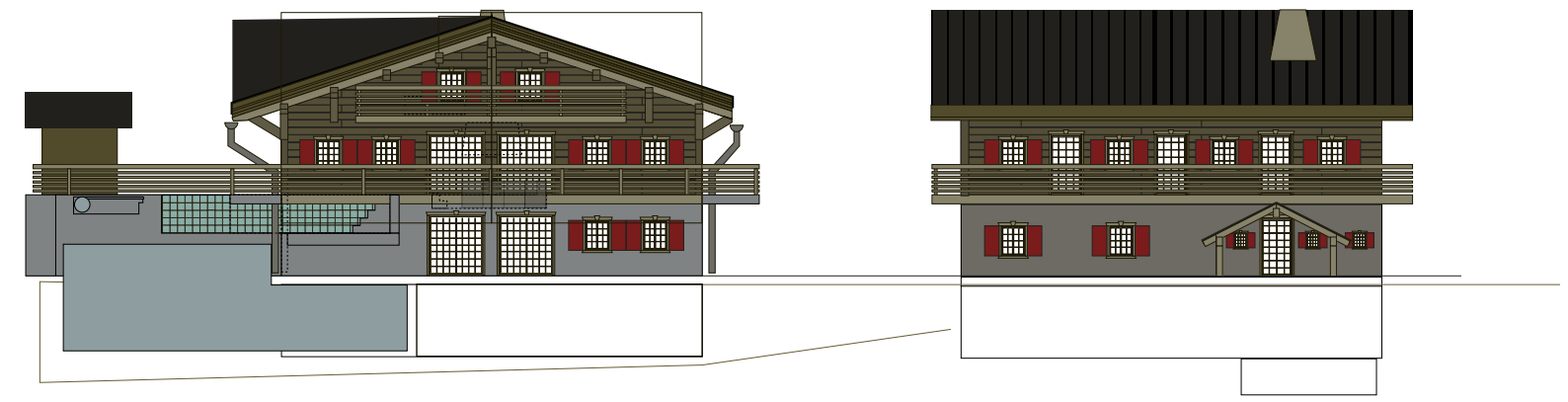
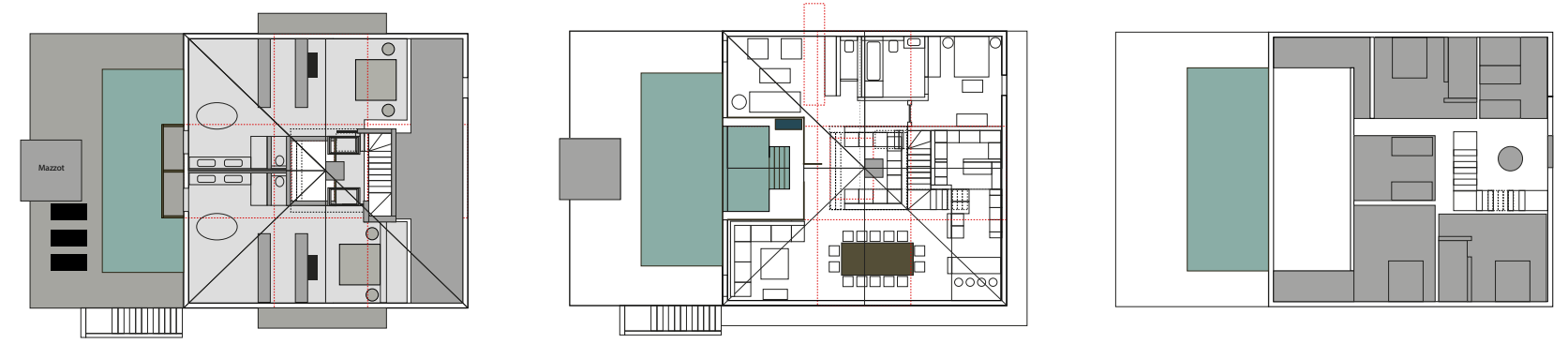
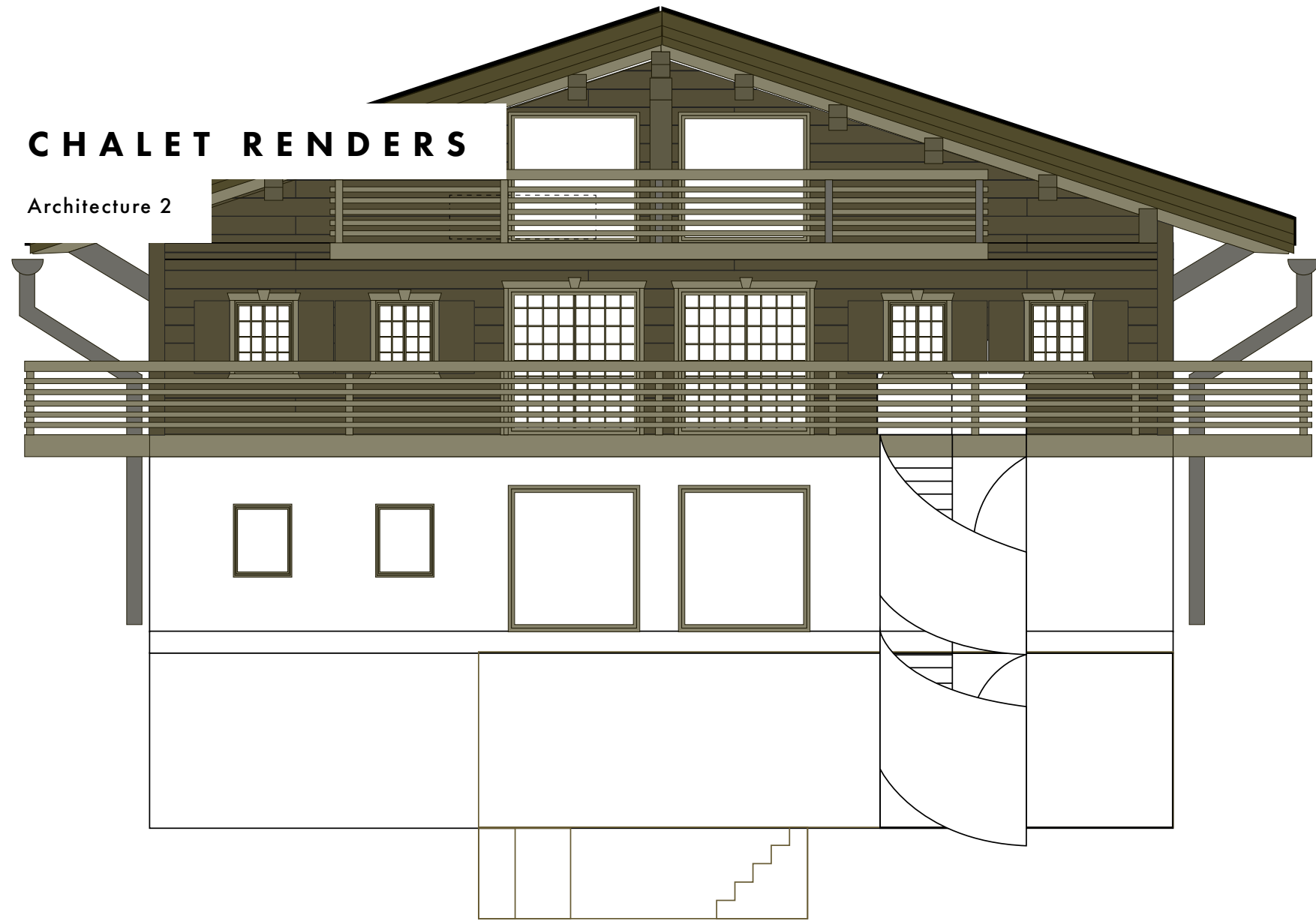

SPA ATRIUM

Architecture 3

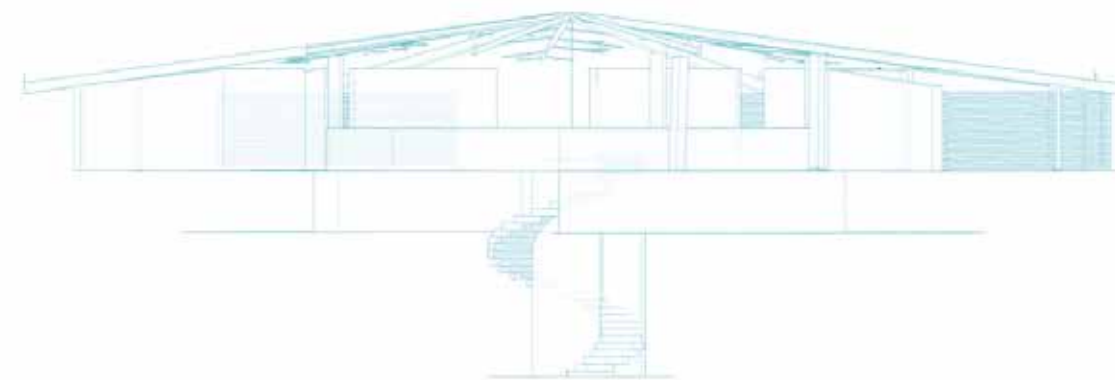
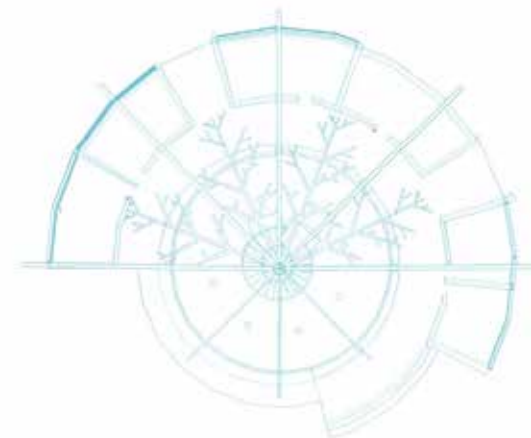
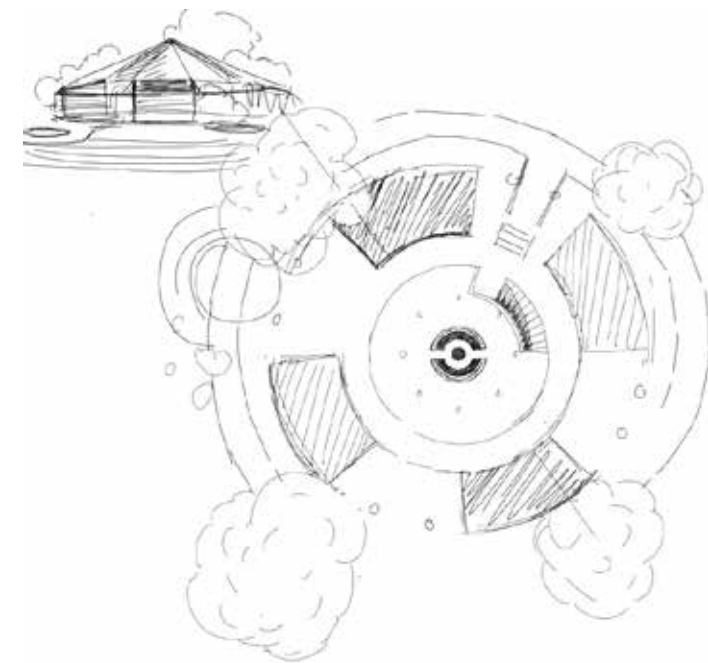
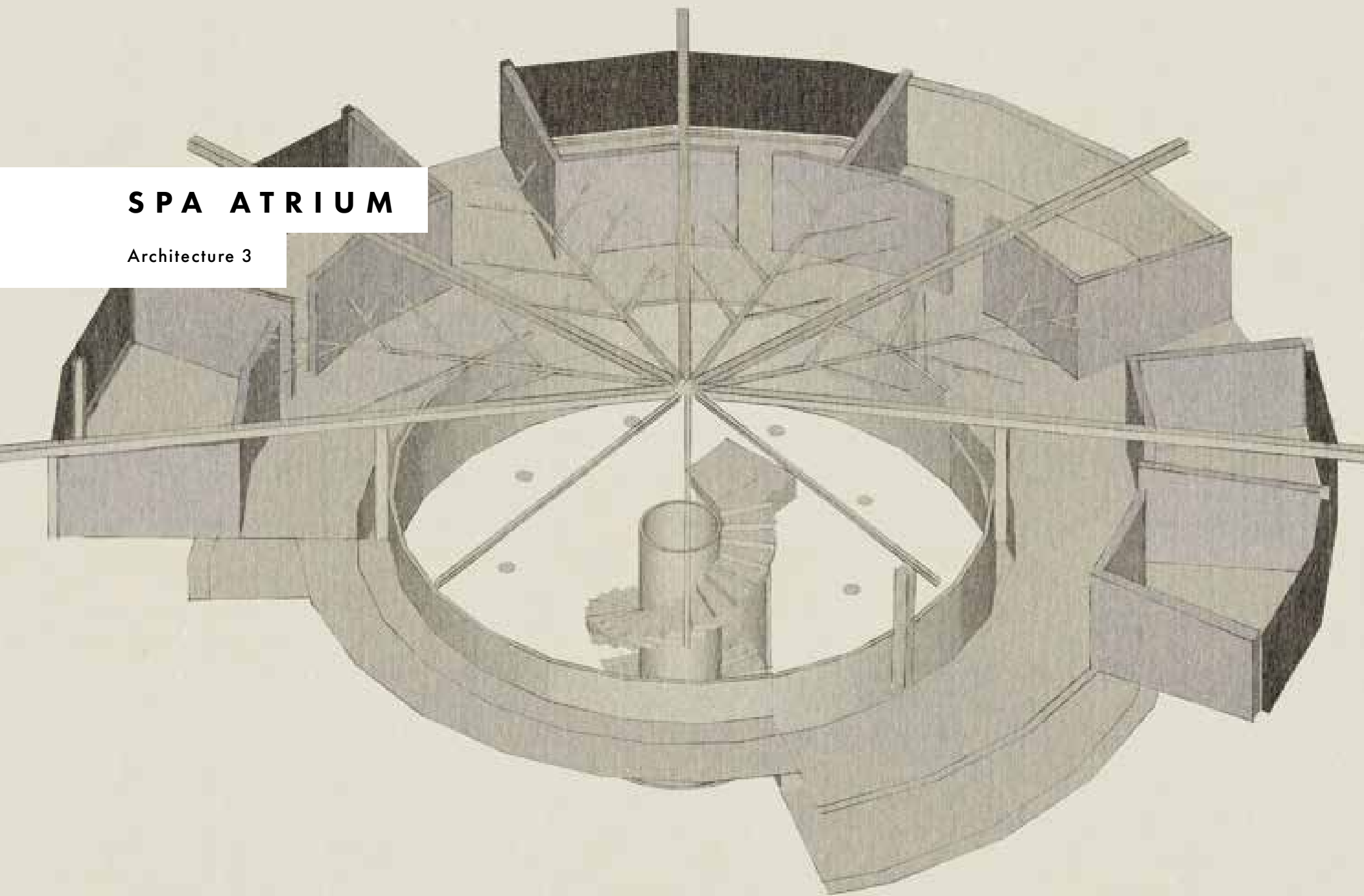

FINE ART / SCULPTURE









CONTACT

We would love to hear from you...

jamie@hipcreativeconsulting.com

+44 (0) 7703 623 922



HIP CREATIVE CONSULTING

hipcreativeconsulting.com





HIPCREATIVECONSULTING.COM